

BO-RO19/28 BO-RO19/28-UV

Reverse Osmosis Unit – optional with UV- sterilisation

BO-RO19/28-UV by BOGA makes it possible for the first time to produce small amounts of purified water cheaply. Its design is made for fully automatic and especially hygienic operation.

Applications

Pressure
Air conditioning
Laboratory
Chemistry
Pharmaceutics
Medicine
Biology
Galvanisation
Cosmetics
Electronics



state-of-the-art technology - extremely economical

TECHNOLOGICAL DESCRIPTION

Natural water is never clean, but full of different substances and particles, especially solved salts. But many production processes, e.g. air humidification, require demineralised water.

This water quality is achieved by the reverse osmosis procedure. Simply said, reverse osmosis can be regarded as filtration. Water containing salt is pressed through a semi-pervious membrane which retains the salts. But also dirt and other particles, causative organisms, larger molecules and even ions can be retained by the membrane and returned as a concentrate to the sewage water.

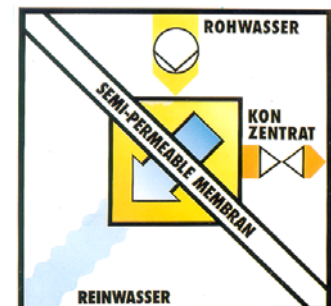

DEVICE DESCRIPTION

BO-RO19/28-UV produces purified water (permeat) of the highest quality without any chemical substances. It can be used for all applications requiring demineralised water, e.g. air conditioning, humidification, in optical and food industry, in the hotel/restaurant sector, in laboratories or in the graphic design industry.

BO-RO19/28-UV consists of pre-filtering, pressure increase system, the activated carbon filter, the 3 RO-membranes, the UV reactor, the permeat saving tank and the control elements.

DESIGN

BO-RO19-UV

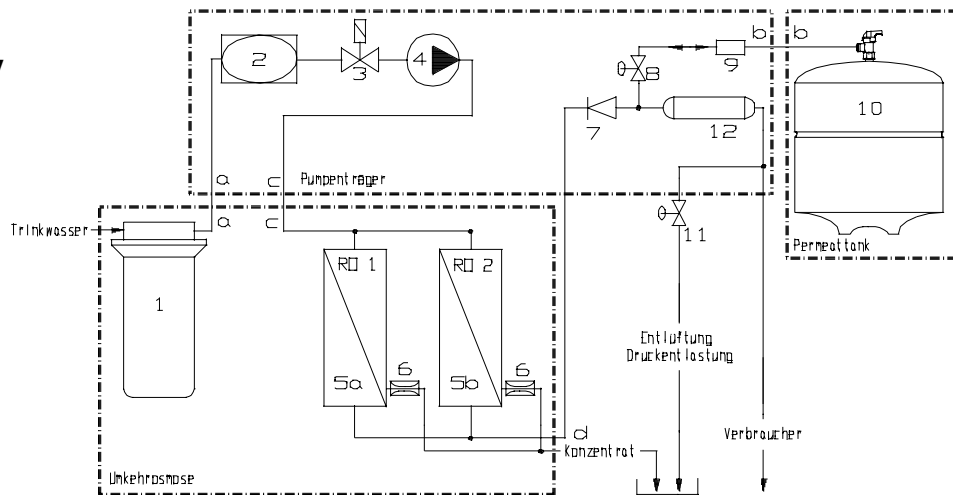

BO-RO28-UV

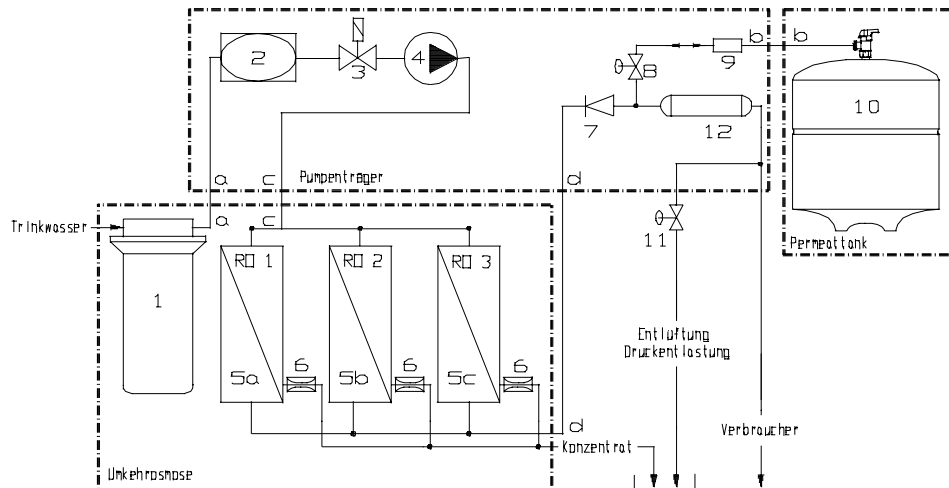

- | | |
|--|---------------------------|
| 1) pre-filter 5µm | 2) manometric switch |
| 3) magnetic valve | 4) booster pump |
| 5) RO membranes (5/a, 5/b, 5/c) | 6) flow control |
| 7) backflow stop | 8) gate valve |
| 9) manometric switch membrane storage tank | 10) membrane storage tank |
| 11) gate valve | |

TECHNICAL SPECIFICATIONS

name	item	BO-RO19	BO-RO28
Components			
Membran Typ		low energy	low energy
number of RO-Membranes	unit	2	3
Membrane dimension	mm	44 x 280	44 x 280
Membrane surface	m ²	0,30	0,45
Configuration		parallel	parallel
UV-Reaktor	unit	1	1
Connections			
water supply	Zoll	¾"	¾"
Permeat	Zoll	3/8" hose	3/8" hose
Concentrate	Zoll	3/8" hose	3/8" hose
Operating condition			
Pressure	bar	2 – 7	2 – 7
Temperatur	°C	5 – 35	5 – 35
pH-Wert		4 – 10	4 – 10
free Chlor Cl ₂	mg/l	< 0,05	< 0,05
hardness CaCO ₃	mg/l	< 85	< 85
Silikat SiO ₂	mg/l	< 10	< 10
Ferric Fe	mg/l	< 0,2	< 0,2
Salinity NaCl	mg/l	< 2.500	< 2.500
Nominal performance			
Water consumption	l/h	38	56
Permeat capacity	l/h	19	28
Concentrate - drain	l/h	19	28
Ratio Concentrate – permeat		1 : 1	1 : 1
Daily production Permeat	l/h	456	672
Detain rate NaCl	%	> 95	> 95
Detain rate Ca ₂ SO ₄	%	> 99	> 99
Permeat tank volume	l	12	12
Permeat tank diameter	mm	280	280
Voltage supply pump	V AC	230	230
power consumption	W	43	43
ambient temperature	°C	2 – 40	2 – 40
water shortage – switchpoint	bar	2	2
Permeattank full – switchpoint	bar	3	3
Permeattank empty - switchpoint	bar	2	2
Weight			
Reverse osmosis - empty	kg	5,8	6,2
Pumpholder – empty	kg	5,2	5,2
Permeat tank - empty	kg	4,3	4,3

MAINTENANCE

Regular maintenance of the BO-RO19/28-UV reverse osmosis system is the proviso for smooth and mainly hygienic operation.

Maintenance refers to the exchange of non-repairable items of the BO-RO6. It can be done in 2 cycles. Each maintenance cycle includes different services. So we offer 2 different maintenance packages.

Cycle	name	item no.	content
BO-RO19/28-UV every 12 months from start-up	maintenance package	50 011 05	UV light unit water filter cartridges 5µ
BO-RO19/28 every 12 months from start-up	maintenance package	50 011 04	water filter cartridges 5µ

ITEM NO. / ACCESSORIES

80 000 19	BO-RO19 reverse osmosis system
80 000 28	BO-RO28 reverse osmosis system
80 001 19	BO-RO19-UV reverse osmosis system inclusive UV- sterilisation
80 001 28	BO-RO28-UV reverse osmosis system inclusive UV- sterilisation
80 000 52	VM- consumption unit – to protect the reverse osmosis from germ and membranes block up, caused by long shutdown time.